



18VDC ESB6-X Series Cordless Screwdrivers Operation Manual



Screwdriver Models : ESB6-X3.5, ESB6-X3.5F, ESB6-X5F
 ESB6-X6, ESB6-X9, ESB6-X12

CAUTION - Please read, understand, and follow all operating and safety instructions in this manual before using the tools.

The 18VDC ESB6-X Series Cordless Electric Screwdrivers are designed for exclusive use with specific Delta Regis batteries and battery chargers as defined in this manual. Do not attempt to use the tools, batteries and/or battery chargers with any products other than as specified in this manual.

If you have any questions or concerns, please contact us at:

**Delta Regis Tools, Inc.
7370 Commercial Circle
Fort Pierce, FL
USA 34951**

**Ph +1-772-465-4302
Fx +1-772-465-4368
E-mail: sales@deltaregis.com
Website: www.deltaregis.com**

Important - Installation and Safety

Warning - Failure to understand and follow proper installation guidelines, safety requirements, and operating instructions may result in malfunction, component damage, property damage, shock hazard, fire hazard, injury or death.

1. Please read and understand the operation manual and follow all safety and operation instructions.
2. Use these products in a suitable dry, indoor location. Do not use the tools, batteries and/or battery chargers in damp, wet or high temperature environments. Do not use in the presence of flammable liquids or gases.
3. Ensure that the battery charger has proper ventilation. Do not expose the tools, batteries and/or battery chargers to areas subject to airborne contaminants (eg. dust, metal filings).
4. Use only a properly grounded electrical outlet of the correct supply voltage to power the battery charger. Ensure that the supply outlet is overload protected and of sufficient amperage capacity.
5. Use only the correct plug for the battery charger. Hold the plug of the power cord when connecting or disconnecting. Do not pull on the cable.
6. Do not expose the tool, battery, battery charger or power cord to oil, chemicals, or heat. Ensure that the power cord is routed and used in such a manner as to not be subject to sharp objects that may abrade or cut the cable.
7. Locate the battery charger in a suitable, safe location on a steady surface. Do not place in a high location where there may be a risk of it falling. Secure the battery charger in position to prevent possible movement caused by pulling on the power cord.
8. Do not cover the battery charger or stack any objects on top of or near the battery charger. Ensure that adequate clearance and ventilation is provided around the perimeter of the battery charger.
9. The 'ESB-CHG' series battery chargers are for use exclusively with Delta Regis brand 18VDC 'ESB-18VL' series lithium-ion batteries as specified on the following pages. Use of the battery charger (or battery) with any product not specified in this manual may result in malfunction, damage, or injury.
10. In the event that the battery charger is overloaded beyond the maximum current rating, an internal fuse will disrupt power. Should the battery charger stop functioning, or exhibit abnormal or intermittent operation, please discontinue use immediately and send the battery charger to an authorized service center for troubleshooting and repair.
11. Excessive duty cycle will cause the tool to overheat. If this occurs, discontinue use until cooled down and reduce cycle rate. As a general rule, do not exceed 10-15 fasteners/minute.
12. The 'ESB6-X' Series cordless screwdrivers incorporate a protection circuit which stops the electric screwdriver if the tool is switched from forward to reverse while running. Should this happen, the operator must release the tool trigger and restart the fastening cycle.
13. Unplug the battery charger if it is not being used on a regular basis.
14. Do not attempt to disassemble or repair the screwdriver, battery or battery charger. Repairs should only be performed by qualified technicians properly trained in the safe operation, troubleshooting, and repair of these devices. Please consult Delta Regis for the location of the nearest service center.
15. Use only the factory specified Delta Regis brand replacement parts and accessories with these tools.
16. Any damage to the tool, battery and/or battery charger resulting from misuse, abuse, or failure to follow these guidelines will void the limited product warranty.

Grounding - The battery charger (and AC power cord) is equipped with a 3-prong electrical receptacle/plug with ground pin. The charger must be connected to a properly grounded AC electrical outlet. Do not attempt to use this charger without a properly functioning ground connection. Never connect a live circuit to the ground pin or internal yellow-green ground wire.

Model Numbers and Specifications

18VDC Cordless Electric Screwdrivers (CE / RoHS)

Model Number	Range Nm	Range In-lbs	Speed (RPM) Hi / Lo	Dimensions (mm) Length x Height	Weight (kg)	Applicable Batteries / Chargers (sold separately, see below)
Models with external torque adjusting nut and reference scale						
ESB6-X3.5	1 - 3.5	9 - 30	1000 / 650	217 x 196 (less battery)	0.79 (less battery)	Battery: ESB-18VL1950B (1.9Ah) Battery Charger: ESB-CHG80/1950B
ESB6-X3.5F	1 - 3.5	9 - 30	2000 / 1300			
ESB6-X6	2 - 6	18 - 53	1000 / 650			
ESB6-X5F	2 - 5	18 - 44	2000 / 1300	233 x 200 (less battery)	1.1 (less battery)	
ESB6-X9	3 - 9	27 - 79	1000 / 650			
ESB6-X12	6 - 12	53 - 106	880 / 570			

18V Lithium Ion Battery for ESB6-X Series Cordless Electric Screwdrivers

18V Li-Ion Battery Model Number	Rating (mAh)	Approx. Rundowns (Full Charge)	Charge Time (80% / Full Charge)	Dim (mm) L x W x H	Weight (g)
ESB-18VL1950B	2000	3000	20 / 30 min.	92 x 90 x 70	430

Battery Charger for ESB-18VL1950B Battery

Battery Charger	Input	Output	Use to charge battery model	Dim (mm) L x W x H	Weight (g)
ESB-CHG80/1950B	90-240 VAC 50/60 Hz	21VDC, 3.2A	ESB-18VL1950B	115 x 145 x 80	530

*Battery Charger shipped with standard North American cord set. For EU cord, add suffix 'E'; for UK cord add suffix 'UK' to part number.

Included Accessories

Item	Quantity
Lock Sleeve	1
Belt Hook	1
Screw for Belt Hook	1
Suspension Bail	1
Philips Power Bit	2
1/4" Hex -> 3/8" Sq Adapter	1
Side Handle (some models)	1
Side Handle Collar (some models)	1
Bolt for Side Handle (some models)	1



ESB-CHG80/1950B
(sold separately)



ESB-18VL1950B
(sold separately)

Quick Set-up and Operation Overview

1. Fully charge the battery using the battery charger before first use to achieve maximum fastening cycles.
2. Ensure that the screwdriver's FWD/REV switch is 'OFF'.
3. Insert the desired driver bit into the quick change chuck of the screwdriver by pushing (or pulling, depending on model) the outer sleeve of the bit holder to release the retainer. Verify that the bit is locked properly in position after installing.
4. Switch the FWD/REV switch to the appropriate direction. Select the desired speed (Hi/Lo) via the switch on the top of the screwdriver.
5. Grip the screwdriver so that the index finger is comfortably over the trigger mechanism. Hold securely to prevent the screwdriver from rotating in your hand during use.
6. Align the driver bit properly in the head of the fastener. Keeping the driver in-line with the fastener, pull and hold the start trigger - the screwdriver will install the fastener (FWD). When the preset torque is reached, the clutch will activate and the tool will shut-off. Once the tool shuts off, release the trigger to reset. To stop the screwdriver before the fastening is complete, release the start trigger.
7. To remove a fastener, change the FWD/REV switch to the REV position. Pull the start trigger to run the driver in reverse (CCW). Do not change the position of the FWD/REV switch while the tool is running.



Setting the Torque

An external torque adjustment nut located at the nose of the screwdriver is used to set the output torque of the driver. A reference scale (0-8) is provided as a guide - this scale is for reference only and does not indicate actual torque values. Rotate the nut clockwise to increase torque output, ccw to decrease torque output. We recommend the use of an appropriate torque tester and static joint testing after installation to verify proper torque settings. Make adjustments through a series of gradual increases, starting below the desired torque and working upwards. Once the desired torque setting is achieved, remove the housing nut and install the torque locking sleeve. This will help avoid accidental torque adjustments.

The output torque of the screwdriver should be verified at regular intervals. The frequency of verification will depend on the individual user's quality control requirements. There may be an initial drop in output torque during the break-in period of the screwdriver.

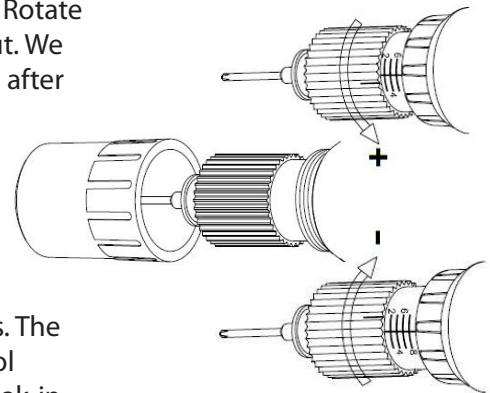

Features Overview

Torque Locking Sleeve

The lock sleeve covers the torque adjusting nut to deter unintentional changes to the adjustment.

Hi/Lo Speed

Switch from high to low speed

Bit Holder

Pull sleeve to insert/remove bits. Once the bit is inserted, release the sleeve and pull back and forth on the bit to verify proper retention.

Housing Nut

Remove the housing nut to install a torque locking sleeve.

FWD/REV Switch

Select the desired direction of rotation for the screwdriver - FWD (CW) or REV (CCW). Center position is 'OFF'.

Belt Hook

Mounting location on left and right for the included belt hook.

Wrist Strap

Helps to prevent the tool from accidentally being dropped.

Torque Adjusting Nut

Turn CW to increase torque setting, CCW to decrease torque output. Higher values on scale indicate a higher torque setting. Please note - Numbers (1-8) on the scale are for reference only and are not actual torque values.

Start Trigger

Pull to start the screwdriver and hold until the driver shuts off (CW tightening).

LED Light

Illuminates dark work areas

Battery Installation / Removal



Insert the battery into the driver as shown. When installed properly the driver will emit a short beep and the LEDs will illuminate momentarily. If the battery is installed incorrectly or too slowly the driver will emit short beeps and the LEDs will flash continuously. If this happens, remove the battery and try again.

To remove the battery, depress the battery release button and slide the battery away from the driver.

Inserting / Removing Power Bits

Insert the desired driver bit into the quick change chuck of the screwdriver by pulling the outer sleeve of the bit holder to release the retainer. Verify that the bit is locked properly in position after installing. Please note, only use 1/4" hex power bits. The use of insert bits will cause the bit to become lodged in the drive shaft. If insert bits must be used, please select an appropriate 1/4" hex bit holder.



Installing / Removing Lock Sleeve (Optional)

Once the desired torque setting is achieved, remove the housing nut by turning it ccw. Install the torque locking sleeve by turning it clockwise until tight. This will help avoid accidental torque adjustments. Note: If the lock sleeve is removed the threaded collar will remain installed on the driver.



LEDs / Buzzer

Rundown Status Indicator

When the driver reaches the set torque and clutches out it will emit a short beep and the green rundown LED will flash once indicating an OK rundown. If the driver does not clutch out before the operator releases the trigger the driver will emit a long beep and the red rundown LED will flash once indicating a NG rundown.

Battery Status Indicator

The ESB6-X Series Cordless Screwdrivers are programmed to avoid poor performance if the battery charge gets too low. When the available battery power reaches 20%, the tool will continue to function and the red battery LED will flash accompanied by several short beeps. When the battery reaches 10% charge, the red battery LED will illuminate for a few seconds accompanied by several beeps. The driver will stop functioning. At this point remove and replace the discharged battery with a fully charged battery to continue production.



OK Rundown LED (Green)

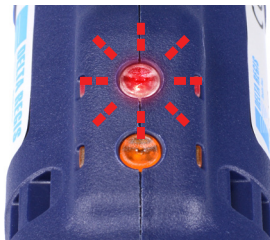

NG Rundown LED (Red)

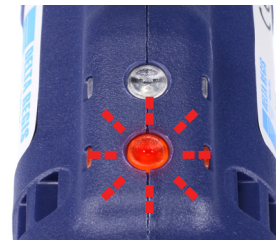

Battery LED (Red)

Side Handle Installation

The supplied side handle improves ergonomics for higher torque ranges by allowing two handed operation. Slide the side handle collar over the front of the tool until it clicks into place. Insert the bolt into the right side of the collar. While holding the bolt in the collar with one hand screw the side handle onto the bolt until tight. To prevent injury on higher torque applications, the accessory side handle must be properly installed and the operator must hold the screwdriver securely with both hands to react the torque.



Parts and Accessories

If you require parts or accessories for your Delta Regis product, please refer to our website or contact us for further information.

Service

The ESB6-X Series cordless electric screwdrivers, batteries and battery chargers are not user serviceable. Any repairs must be performed by a Delta Regis authorized service center. Please consult Delta Regis Tools for further information and the location of the nearest authorized service center.

Repairs to the ESB6-X Series cordless electric screwdrivers, batteries and battery chargers must be performed by trained personnel, knowledgeable and qualified in the repair of DC electric screwdrivers.

Use only genuine Delta Regis parts when servicing these products.

Do not attempt to modify the tools, batteries or battery chargers.

Warranty

The ESB6-X Series cordless electric screwdrivers, batteries and battery chargers are warranted for one year from the date of purchase against defects in material and workmanship. In addition, the brushless motor in the ESB6-X Series cordless screwdrivers is warranted for three years from the date of purchase against defects in material and workmanship. This warranty does not cover damage due to transportation, abuse, misuse, or improper service. Our sole remedy is to repair or replace (at our discretion) any unit found to be defective due to defects in material or workmanship. It is the responsibility of the user to return any product thought to be defective, freight prepaid, to our warehouse for inspection and evaluation.

There is no warranty of merchantability or fitness of purpose. In no event will Delta Regis Tools, Inc. be liable for business interruptions, loss of profits, harm, injury, damage, personal injury, cost of delay, or any other special, indirect, incidental, or consequential losses, costs, or damages.