

ESB6 CORDLESS SHUT-OFF CLUTCH NUT-RUNNERS

Angle Type Brushless High Torque Battery Screwdrivers Series

Torque Range:
2–60 Nm (1.5–44.2 ft-lbs)

Features:

- Precise shut-off clutch provides excellent repeatability and minimizes torque reaction to the operator
- Hi/Lo speed selection switch on nutrunner
- Powerful DC brushless motor
- High performance 18VDC Li-Ion batteries (purchased separately)
- Front facing LED illuminates fastening area when the trigger is pulled
- To conserve battery life, the screwdriver goes into sleep mode when idle for more than 3 seconds
- Includes swivel bail for suspending from tool balancer
- Long service life — Factory tested to 2,000,000 cycles
- Green/Red LEDs and audible indicators alert operator of proper clutch function at shut-off
- Charging station (purchased separately) provides quick recharge time



Specifications

Model	ESB6-RA5F	ESB6-RA7	ESB6-RA12	ESB6-RA15	ESB6-RA15F	ESB6-RA8F	ESB6-RA30	ESB6-RA45	ESB6-RA60	
Input Voltage	18V									
Torque	Hard Joint	2-5 Nm 1.5-3.7 ft-lbs	2.5-7 Nm 1.8-5.2 ft-lbs	6-12 Nm 4.4-8.8 ft-lbs	8-15 Nm 5.9-11 ft-lbs	8-15 Nm 5.9-11 ft-lbs	3-8 Nm 2.2-6 ft-lbs	12-30 Nm 8.8-22.1 ft-lbs	15-45 Nm 11-33.1 ft-lbs	25-60 Nm 18.4-44.2 ft-lbs
	Soft Joint	2-4 Nm 1.5-3 ft-lbs	2.5-5.6 Nm 1.8-4.1 ft-lbs	6-9.6 Nm 4.4-7.1 ft-lbs	8-12 Nm 5.9-8.8 ft-lbs	8-12 Nm 5.9-8.8 ft-lbs	3-6.4 Nm 2.2-4.7 ft-lbs	12-24 Nm 8.8-17.7 ft-lbs	15-36 Nm 11-26.5 ft-lbs	25-48 Nm 18.4-35.4 ft-lbs
Repeatability	±5%									
Torque Adjustment	Internal Stepless									
Free Speed (RPM) ±10%	Hi	1200	850	550	350	850	1200	350	200	200
	Lo	800	550	350	220	550	800	220	130	130
Weight (w/o battery)	1.25 kg / 2.6 lbs		1.5 kg / 3.3 lbs	1.85 kg / 4.0 lbs		1.9 kg / 4.2 lbs		2.85 kg / 6.3 lbs		
Length (w/o battery)	400 mm / 15.7 in		415 mm / 16.3 in	440 mm / 17.3 in		450 mm / 17.7 in		530 mm / 20.9 in		
Applicable Battery	ESB-18VL3000B				ESB-18VL3000C			ESB-18VL3900		
Applicable Charger	ESB-CHG80/1950B							ESB-CHG80N		
Drive Size	1/4" Hex		3/8" Sq 1/4" Hex			3/8" Sq		1/2" Sq		

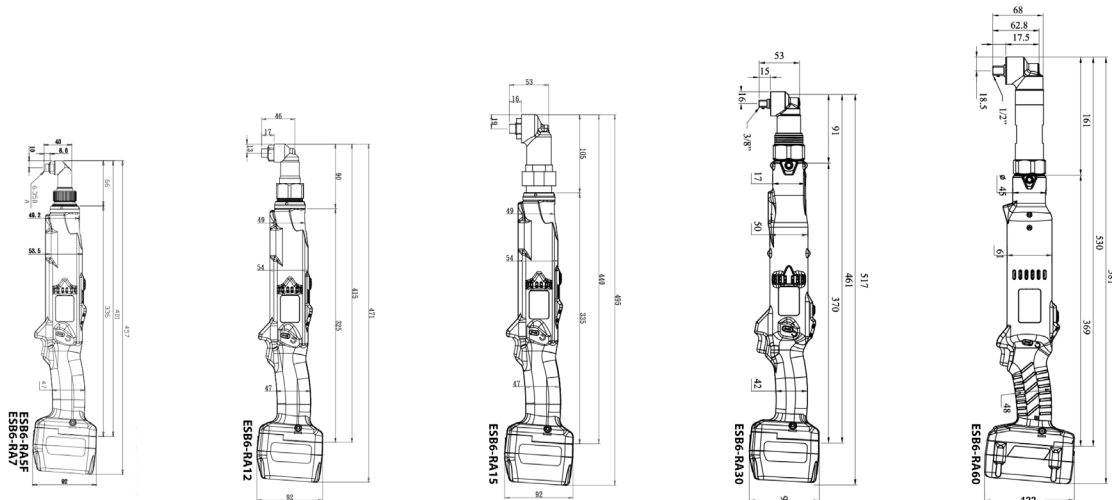

LITHIUM ION BATTERIES & BATTERY CHARGERS

Charge Stations: ESB-CHG70, ESB-CHG80, ESB-CHG80/1950B

Rechargeable Batteries: ESB-18VL1950(B), ESB-18VL3000B/C, ESB-18VL3900



Lithium-Ion Batteries

High performance lithium-ion batteries allow the ESB6 Series Screwdrivers to perform a high quantity of fastening cycles between charges. In some instances, two battery sizes are available - a standard (1950 mAh) battery and an extended life (3900 mAh) battery.

Display Description

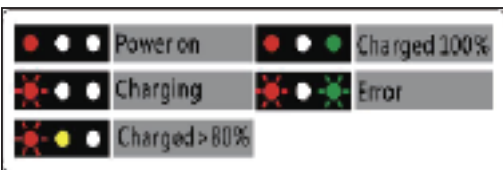

Li-Ion Battery Model Number	Rating (mAh)	Use with tool models	Dim (mm)(in) L x W x H	Weight (g)(lbs)
ESB-14VL3000	3000	Refer to Screwdriver Model Chart	107 x 75 x 43(mm) 4.2 x 2.9 x 1.7(in)	320g/0.7lbs
ESB-18VL3000B/C	3000		92 x 75 x 70(mm) 3.6 x 3.0 x 2.4(in)	430g/1lbs
ESB-18VL1950	1950		119 x 90 x 40(mm) 4.7 x 3.5 x 1.6(in)	430g/1lbs
ESB-18VL3900	3900		119 x 90 x 59(mm) 4.7 x 3.5 x 1.6(in)	720g/1.6 lbs

Battery Chargers

The ESB-CHG Battery Chargers quickly recharge the cordless screwdriver's batteries so that they are ready when needed. The charger is capable of bringing a standard battery to an 80% charge level in about 25 minutes.

Features include:

- Battery identification to help protect against charging the wrong brand/type of battery.
- Over-temperature protection, output over-voltage protection.
- Audible and visual indication when battery reaches full charge.
- ETL / CE Compliant.

Indicator lights provide visual indication of:

- Power On
- Battery Charging
- Charge exceeds 80%
- Fully Charged
- Charging Error



Approximate Battery Charge Times

Battery Model/ Capacity	ESB-CHG120	ESB-CHG70	ESB-CHG80	ESB-CHG80/1950B
ESB-14VL3000 (3000mAh)	-	40 min	-	-
ESB-18VL1950 (1950mAh)	40 min.	-	40 min.	-
ESB-18VL3900 (3900mAh)	60 min.	-	80 min.	-
ESB-18VL3000B/C (3000mAh)	-	-	-	40 min.

Battery Charger	Input	Output	Use to charge battery model	Dim (mm)(in) L x W x H	Weight (g)(lbs)
ESB-CHG80/1950B (1820B only)	90-240 VAC 50/60 Hz	21VDC, 3.2A	ESB-18VL3000B/C	145 x 115 x 75(mm) 5.7 x 4.5 x 2.9(in)	460g/1.0lbs
ESB-CHG70 (standard charger)		16.8V, 3.2A	ESB-14VL3000	107 x 75 x 43(mm) 4.2 x 2.9 x 1.7(in)	530g/1.2lbs
ESB-CHG80 (standard charger)		21VDC, 3.2A	ESB-18VL1950/ESB-18VL3900	115 x 145 x 80(mm) 4.5 x 5.7 x 3.1(in)	530/1.2lbs