

# INDUSTRIAL AUTO SHUT-OFF IMPACT DRIVER

## Features

- With a maximum of 99 x 6 possible combinations the tool can be dialed in to your specific torque requirement.
- OK & NG indicators (Sound & Lights) provide instant feedback for cross threading and screw stripping errors
- Use up to 5 customizable program settings in sequence
- Programmable batch count function shows number of fasteners remaining in batch
- Programming is completed with DR-IRC1 remote control and has the capability to lock settings on the tool to avoid accidental or intentional tampering
- Reverse run (Counter-clockwise operation) function
- Ignore friction function helps to further increase repeatability when working with multiple joint types and material

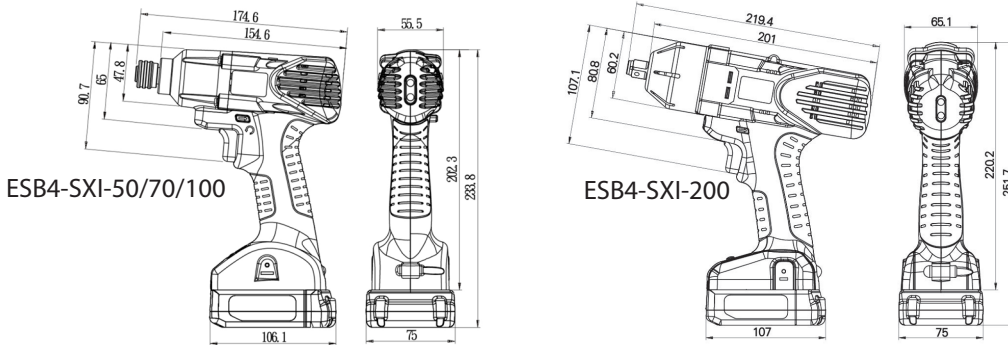

## Specifications

Model	ESB4-SXI-50	ESB4-SXI-70	ESB4-SXI-100	ESB4-SXI-200
Input Voltage	14.4V			
Speed (RPM)	0~1900	0~2600	0~2000	0~1700
BPM	0~2500	0~3400	0~2600	0~2100
Torque Range	5~50 Nm (3.7~36.9 ftlb)	20~70 Nm (14.7~51.6 ftlb)	20~100 Nm (14.7~73.7 ftlb)	25~200 Nm (18.4~147.5 ftlb)
Recommended Fastener Size (Class 12.9)	M6 / M8 / M10 / M12	M8 / M10 / M12 / M14	M10 / M12 / M14 / M16	M12 / M14 / M16 / M20
Torque Range Capability (Based on fastener size)	M6 - 3~20Nm (2.2~14.7 ftlb)	M8 - 8~30Nm (5.9~22.1 ftlb)	M10 - 8~40Nm (5.9~29.5 ftlb)	M12 - 15~110Nm (11.0~81.1 ftlb)
	M8 - 3~20Nm (2.2~14.7 ftlb)	M10 - 8~40Nm (5.9~29.5 ftlb)	M12 - 20~70Nm (14.7~51.6 ftlb)	M14 - 25~120Nm (18.4~88.5 ftlb)
	M10 - 5~30Nm (3.7~22.1 ftlb)	M12 - 20~60Nm (14.7~44.2 ftlb)	M14 - 20~90Nm (14.7~66.3 ftlb)	M16 - 25~140Nm (18.4~103.2 ftlb)
	M12 - 12~50Nm (8.8~36.9 ftlb)	M14 - 25~70Nm (18.4~51.6 ftlb)	M16 - 28~100Nm (20.6~73.7ftlb)	M20 - 25~200Nm (18.4~147.5 ftlb)
Drive Type	1/4" Hex		3/8" Square	1/2" Square
	3/8" Square *Add suffix "-SQ"*		**Available in 1/2" Square Special Order**	
Weight (Less Battery)	0.98 kg (2.1 lbs)	1.0 kg (2.2 lbs)		1.5 kg (3.3 lbs)
Dimensions (Less Battery)	174x202mm (6.8x7.8")			219x220mm (8.6x8.7")
Battery	ESB-14VL3000			
Charger	ESB-CHG70			
Optional Accessories	DR-IRC1			

# LITHIUM ION BATTERIES & BATTERY CHARGERS

## Charge Stations: ESB-CHG70, ESB-CHG80, ESB-CHG80/1950B

## Rechargeable Batteries: ESB-18VL1950(B), ESB-18VL3000B/C, ESB-18VL3900



### Lithium-Ion Batteries

High performance lithium-ion batteries allow the ESB6 Series Screwdrivers to perform a high quantity of fastening cycles between charges. In some instances, two battery sizes are available - a standard (1950 mAh) battery and an extended life (3900 mAh) battery.

### Display Description

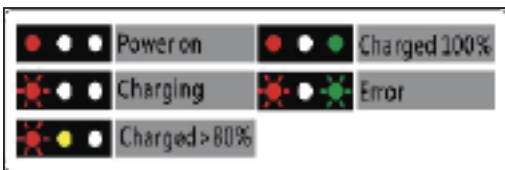

Li-Ion Battery Model Number	Rating (mAh)	Use with tool models	Dim (mm)(in) L x W x H	Weight (g)(lbs)
ESB-14VL3000	3000	Refer to Screwdriver Model Chart	107 x 75 x 43(mm) 4.2 x 2.9 x 1.7(in)	320g/0.7lbs
ESB-18VL3000B/C	3000		92 x 75 x 70(mm) 3.6 x 3.0 x 2.4(in)	430g/1lbs
ESB-18VL1950	1950		119 x 90 x 40(mm) 4.7 x 3.5 x 1.6(in)	430g/1lbs
ESB-18VL3900	3900		119 x 90 x 59(mm) 4.7 x 3.5 x 1.6(in)	720g/1.6 lbs

### Battery Chargers

The ESB-CHG Battery Chargers quickly recharge the cordless screwdriver's batteries so that they are ready when needed. The charger is capable of bringing a standard battery to an 80% charge level in about 25 minutes.

#### Features include:

- Battery identification to help protect against charging the wrong brand/type of battery.
- Over-temperature protection, output over-voltage protection.
- Audible and visual indication when battery reaches full charge.
- ETL / CE Compliant.

#### Indicator lights provide visual indication of:

- Power On
- Battery Charging
- Charge exceeds 80%
- Fully Charged
- Charging Error



Approximate Battery Charge Times

Battery Model/ Capacity	ESB-CHG120	ESB-CHG70	ESB-CHG80	ESB-CHG80/1950B
ESB-14VL3000 (3000mAh)	-	40 min	-	-
ESB-18VL1950 (1950mAh)	40 min.	-	40 min.	-
ESB-18VL3900 (3900mAh)	60 min.	-	80 min.	-
ESB-18VL3000B/C (3000mAh)	-	-	-	40 min.

Battery Charger	Input	Output	Use to charge battery model	Dim (mm)(in) L x W x H	Weight (g)(lbs)
ESB-CHG80/1950B (1820B only)	90-240 VAC 50/60 Hz	21VDC, 3.2A	ESB-18VL3000B/C	145 x 115 x 75(mm) 5.7 x 4.5 x 2.9(in)	460g/1.0lbs
ESB-CHG70 (standard charger)		16.8V, 3.2A	ESB-14VL3000	107 x 75 x 43(mm) 4.2 x 2.9 x 1.7(in)	530g/1.2lbs
ESB-CHG80 (standard charger)		21VDC, 3.2A	ESB-18VL1950/ESB-18VL3900	115 x 145 x 80(mm) 4.5 x 5.7 x 3.1(in)	530/1.2lbs